

## A cost-efficient, robust solution that gives you the benefit of high productivity and savings

The IN Series is a well proven design and an efficient pulse-jet cleaning system. Insertable (IN) Jet Pulse filters are modular bag filters in which the dust-laden air enters through the base and is evenly distributed between the filter bags. This ensures a smooth flow of both coarse and fine particles into the filter.

### Benefits

#### Efficiency

- The pulse jet system automatically cleans the bags row-by-row even as the dust is being filtered. The advantage is that the filter continues to work while the bags are being cleaned.

#### Savings

- Being a low maintenance solution, the IN needs minimum downtime. This means continuous plant operations for you.
- The filter control system helps maintain a low pressure drop – helping you save both compressed air and energy.
- The filter module comes in three sizes: 24, 36 and 54 cylindrical bags mounted on wire cages 1.5 m in length and 127 mm in diameter.

#### Flexibility

- You can separate almost any kind of dust – fine, or abrasive.



### Features

- Capacity: 500 – 4.500 m<sup>3</sup>/h
- Filter size: 13.1 – 29.7 m<sup>2</sup> filter surface
- Standard 4.5% vacuum (450 mmWC)

Subject to alterations

## Dimensioning:

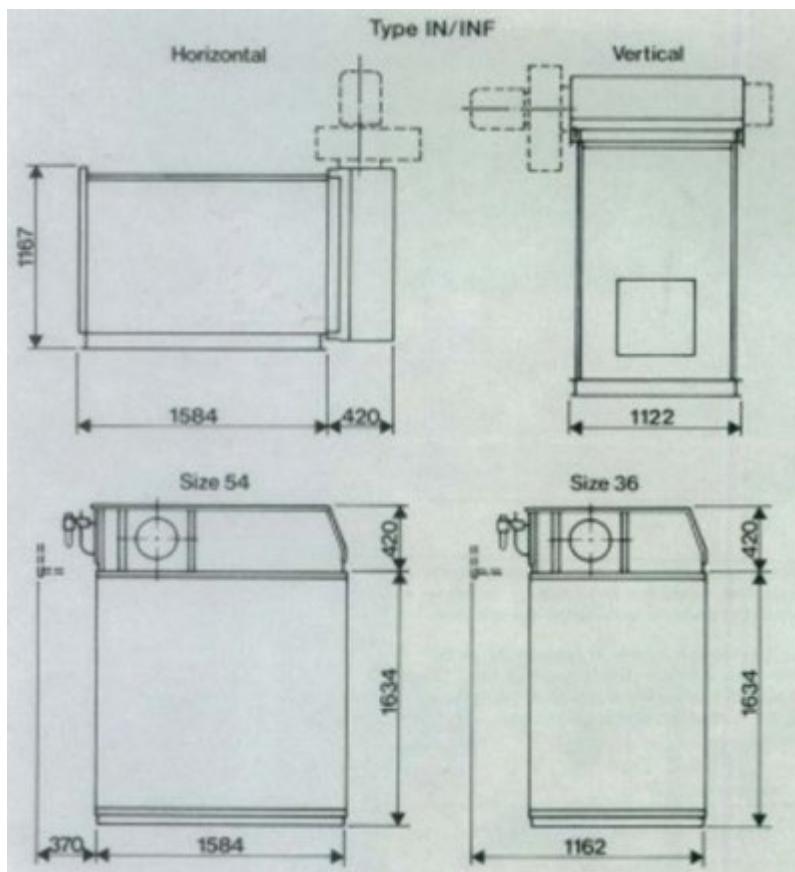
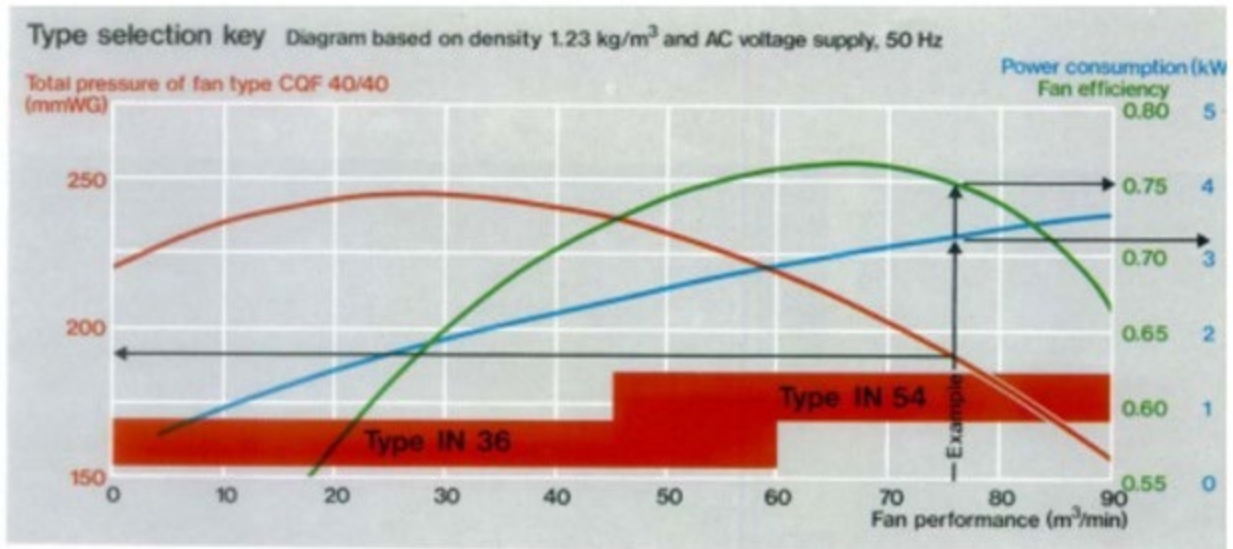

### Example:

A material conveyor to be dedusted at an air temperature below  $80^\circ\text{C}$  at a rate of  $75 \text{ m}^3/\text{min}$ .

### Solution:

Insertable Jet Pulse Filter type INF 54 is recommended.

The CQF 40/40 fan will work at an efficiency of 0.75 with at total pressure of 180 mm WG and with a power consumption of 3.2 kW.

For temperatures between  $80^\circ\text{C}$  and  $200^\circ\text{C}$  an insertable Jet Pulse Filter, type IN 54 with special bags and separate fan is recommended.

For larger filter sizes, please contact Simatek's sales department.

### Industries we serve for emission control and product recovery (detailed industry segments on our homepage)

- Cement & Lime
- Grain & Feed
- Energy & Waste
- Food & Dairy
- Speciality Powder
- Chemical & Mineral resources