

## An efficient aspiration system that handles bulk dust loads and creates a safe, clean working environment

Simatek central vacuum cleaning system ensures a well dimensioned aspiration system that performs efficiently. It helps create a safe, clean working environment with optimal work conditions.

We provide different types of ducts – mild steel or stainless steel – that are assembled with easy-to-detach pipes.

### Benefits

#### Efficiency

- A clean working environment with reduced noise and vibration means that the employees can work efficiently and without distractions.

#### Safety

- For plants operating with explosive dust, Simatek central vacuum cleaning system's quick and efficient cleaning ensures a safe working environment.

#### Savings

- Dusty and unsafe work environments can make the staff ill. With our central vacuum cleaning system a clean and safe working environment can be ensured and avoid losses due to a high number of sick days.

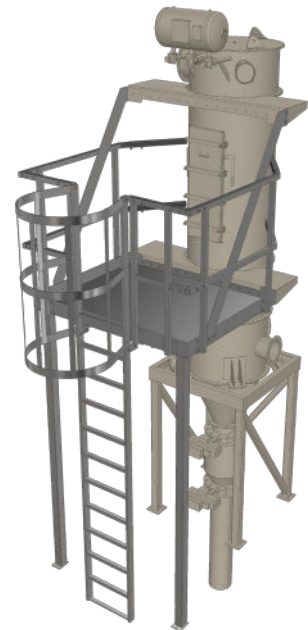

### Features

#### Ease of use

- Easy to operate
- Quick and efficient cleaning
- Adaptable to different dust types

#### Effective design

- Sufficient suction capacity to handle bulk dust loads
- No circulation of air
- Low emissions

#### Standards

- TÜV approved following German standard VDI2263
- Applying with ATEX Directive
- High level of documentation

### Construction forms

#### Inlets

17 - radial inlet with baffle plates

#### Top

4T-R – flat top cover, installation/change of bags through man door

4T2-R - hinged top cover, installation/change of bags from the clean-air side

### Applications

- |                           |                     |                      |                       |
|---------------------------|---------------------|----------------------|-----------------------|
| • Grain and feed industry | • Brewery           | • Fish feed industry | • Mineral industry    |
| • Chemical industry       | • Paper industry    | • Pet-food industry  | • Fertiliser industry |
| • Cement industry         | • Plastics industry | • Recycling industry |                       |
| • Food industry           | • Metal industry    | • Wood industry      |                       |

## Dimensioning

SimVac is dimensioned from 3 to 110 kW, depending on capacity and application.

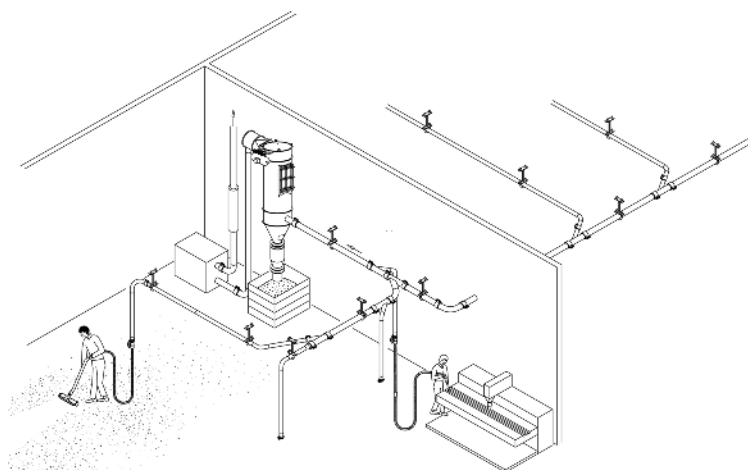

Information required for quotation for central vacuum cleaning system.

**Company**

**Contact person:**

**E-mail**

**Tel. no.**

1.	Name of project		
2.	Total number of suction points		pcs.
3.	Number of suction points in concurrent operation	ø38 mm	pcs. (cleaning of machinery)
		ø50 mm	pcs. (floor cleaning)
4.	Max. distance from the filter to the farthest suction point		m
5.	Product / type of dust		
6.	Number of storeys		
7.	In case of more than one storey, please inform at which storey the filter is to be installed		
8.	How will dust collection after the filter take place	Box Big-bag	Dust bin Trough conveyor
9.	Explosion venting of the filter	Yes: Kst value:	No: Pmax value:

To be returned to [office@simatek.com](mailto:office@simatek.com)